

# DI16 081M. 515 kW (700 hp)

US Tier 3



The marine engines from Scania are based on a robust design with a strength optimised cylinder block containing wet cylinder liners that can easily be exchanged. Individual cylinder heads with 4 valves per cylinder promotes reparability and fuel economy. The engines are type approved in all major classification societies.

The engine is equipped with a Scania developed Engine Management System, EMS, in order to ensure the control of all aspects related to engine performance. The injection system is based on electronically controlled unit injectors that gives low exhaust emissions with good fuel economy and a high torque already at low revs. The engine can be fitted with many accessories such as air cleaners, PTOs, transmissions and type approved instrumentation in order to suit a variety of installations.

	Rating	Engine speed (rpm)			
		1200	1500	1800	2100
Gross power, full load (kW)	IFN	302	423	488	515
Gross power, full load (hp, metric)		411	575	664	700
Gross power, propeller curve (kW)		127	222	350	515
Gross power, propeller curve (hp, metric)		173	302	476	700
Gross torque (Nm)		2406	2693	2590	2342
Spec fuel consumption. Full load (g/kWh)		197	194	198	219
Spec fuel consumption. 3/4 load (g/kWh)		196	199	206	229
Spec fuel consumption. 1/2 load (g/kWh)		202	204	212	242
Spec fuel consumption. Propeller curve (l/h)		31	54	86	134
Optimum fuel consumption (g/kWh)		194			
Heat rejection to coolant (kW)		229	302	364	452

**IFN - Intermittent service:** Intended for intermittent use where rated power is available 1 hour/3 hours period. Accumulated load factor must not exceed 80% of rated power. Unlimited h/year service time.

### Standard equipment

- Scania Engine Management System, EMS
- Unit injectors, PDE
- Twin turbochargers, heat insulated
- Fuel pre-filter with water separator
- Fuel filter
- Oil filter, full flow
- Centrifugal oil cleaner
- Oil cooler, integrated in block
- Oil filler, in valve cover
- Deep front oil sump
- Oil dipstick, front
- Starter, 2-pole 7.0 kW
- Alternator, 2-pole 100A
- Flywheel SAE 14
- Silumin flywheel housing, SAE 1 flange
- Front-mounted engine brackets
- Catwalk and cover for belt transmission
- Closed crankcase ventilation
- Operator's manual

### Engines with heat exchanger:

- Sea water pump
- Dual heat exchangers with expansion tanks

### Optional equipment

- Electrical base system
- Accelerator position sensor
- Control panel
- Instrument panel
- Scania EMS display
- Hydraulic pump
- Side-mounted PTO
- Front-mounted PTO
- Exhaust connections
- Engine heater
- Power pack engine brackets
- Stiff rubber suspension
- Air cleaner
- Studs in flywheel housing
- Reversible fuel filter
- Low coolant level reaction
- Variable idle speed setting
- Low oil sump
- Oil draining with pump
- Oil level sensor
- Bilge pump

This specification may be revised without notice.

# DI16 081M. 515 kW (700 hp)

## US Tier 3

### Engine description

No of cylinders	V 8
Working principle	4-stroke
Firing order	1 - 5 - 4 - 2 - 6 - 3 - 7 - 8
Displacement	16.4 litres
Bore x stroke	130 x 154 mm
Compression ratio	16.7:1
Weight	1670 kg (excl oil and coolant)
Piston speed at 1500 rpm	7.7 m/s
Piston speed at 1800 rpm	9.24 m/s
Camshaft	High position alloy steel
Pistons	Steel pistons
Connection rods	I-section press forgings of alloy steel
Crankshaft	Alloy steel with hardened and polished bearing surfaces
Oil capacity	40-48 dm <sup>3</sup> (standard oil sump)
Electrical system	2-pole 24V

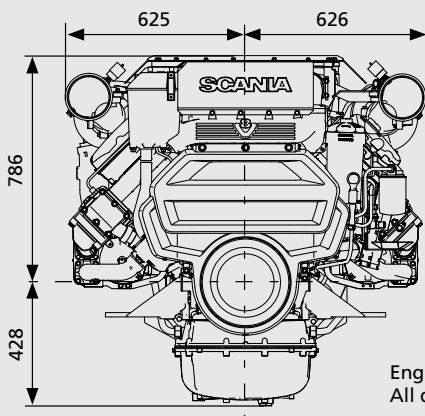
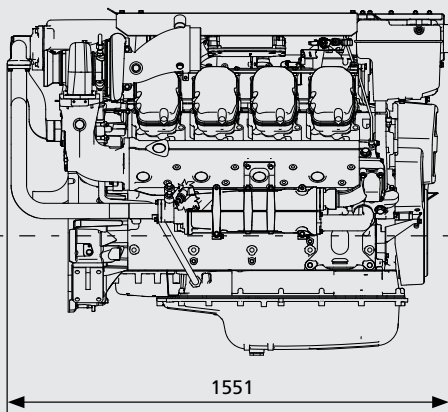

Engine with heat exchanger  
All dimensions in mm

### Output

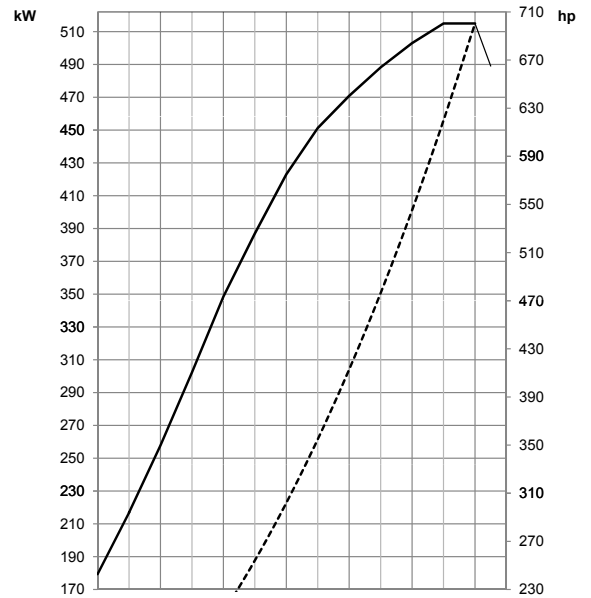

### Torque

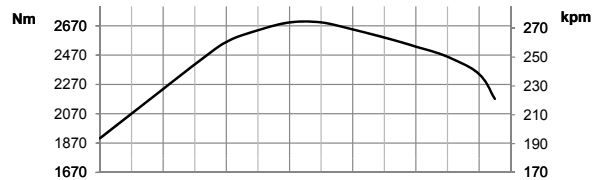

### Spec fuel consumption

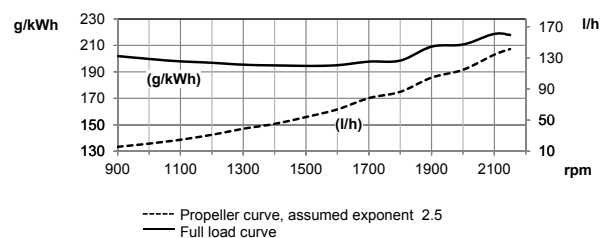

Test conditions Air temperature +25°C. Barometric pressure 100 kPa (750 mmHg). Humidity 30%. Diesel fuel acc. to ECE R 24 Annex 6. Density of fuel 0.840 kg/dm<sup>3</sup>. Viscosity of fuel 3.0 cSt at 40°C. Energy value 42700 kJ/kg. Power test code ISO 3046. Power and fuel values +/-3%.



**SCANIA**

SE 151 87 Södertälje, Sweden  
Telephone +46 8 553 810 00  
Telefax +46 8 553 829 93  
www.scania.com  
engines@scania.com